

P22

SERVO SWINGER

Off-Air Servo Driver



This simple off-air servo driver works by generating the standard +ve signal pulse from a timer circuit. It uses a separate battery box with 4 x AA alkaline or NiCad/NiMH cells, or you might replace this with a 4.8v battery pack such as the one from your RC gear. This means that you no longer have to scabble around looking for your Tx, a spare receiver (*with the correct crystal fitted....*) and a wiring harness to set up your new model or check a suspect servo. The 1.5 mS neutral is standard for practically all modern RC systems. It is such a useful item for testing and setting up servos, RC switchers and electronic speed controllers that you'll wonder how you managed without it.

INTEGRATED CIRCUIT DESIGN

Pulse length	1 mS - 2 mS
Frame rate	20 mS +/- 10%
Battery voltage	4.8v (4 x NiCad/NiMH) to 6v (4 x AA Alkaline)
Current requirement	<10 mA
Case size	64mm x 44mm x 25mm with screws
Input	Via rotary knob
Output	Via male servo lead

Battery box, clip and servo lead are supplied with both kit and ready-built units.

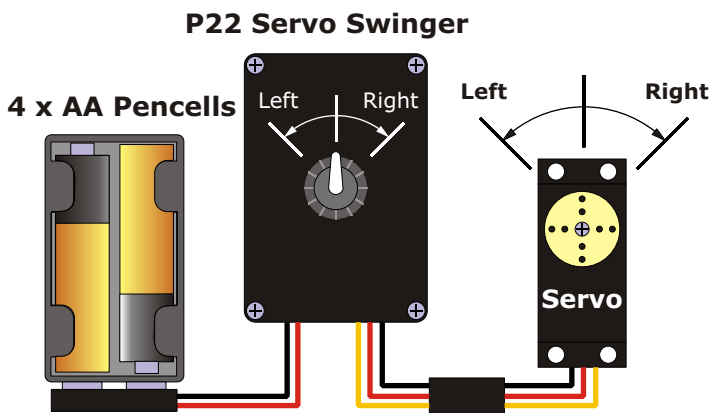
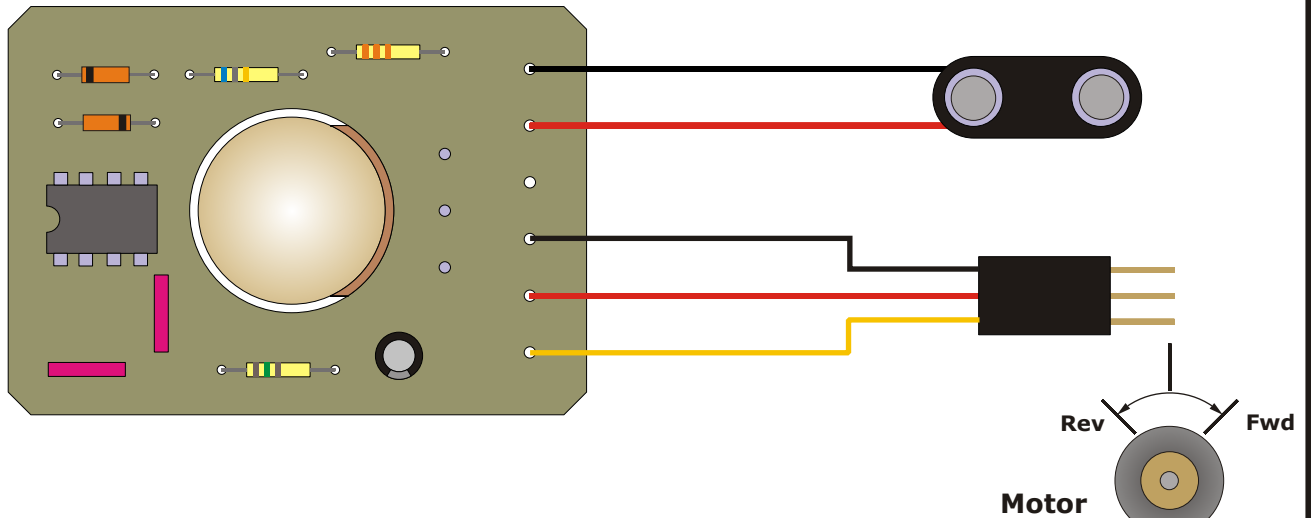

P22 CONNECTED TO A SERVO

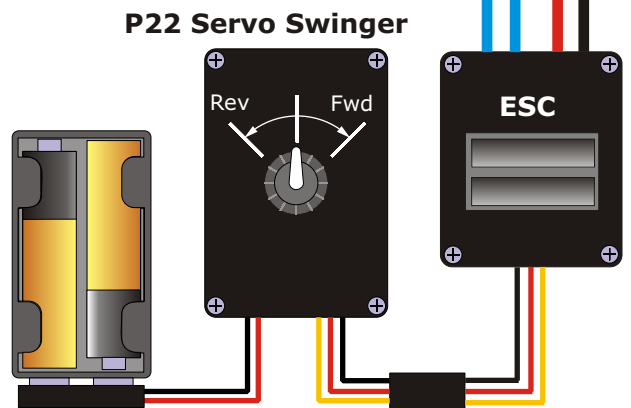

P22 CONNECTED TO AN ELECTRONIC MOTOR SPEED CONTROLLER

P22

SERVO SWINGER

Off-Air Servo Driver



This simple off-air servo driver works by generating the standard +ve signal pulse from a timer circuit. It uses a separate battery box with 4 x AA alkaline or NiCad/NiMH cells, or you might replace this with a 4.8v battery pack such as the one from your RC gear. This means that you no longer have to scabble around looking for your Tx, a spare receiver (*with the correct crystal fitted...*) and a wiring harness to set up your new model or check a suspect servo. It is such a useful item for testing and setting up servos, R/C switchers and electronic speed controllers that you'll wonder how you managed without it.

Pulse length	Approx 0.8 mS 2.2 mS
Frame rate	20 mS +/- 10%
Maximum Battery voltage	4.8v (4 x NiCad/NiMH) or 6v (4 x AA Alkaline)
Current requirement	<10 mA
Case size	64mm x 44mm x 25mm with screws
Input	Via rotary knob
Output	Via male servo lead

SETUP

1. Use a servo from your RC system to set up the Servo Swinger. Note the position of the servo disc when the transmitter stick and trim lever are both centred. Mark this centre position on the servo.
2. Connect the battery pack and the servo to the P22.
3. Turn the spindle of VR1 until the servo disc is in the same (neutral) position which you marked earlier.
4. Fit the knob to the spindle and scribe a mark on the case to correspond with the neutral position.

NOTE Maximum Voltage, BEC & Electronic Speed Controllers

You should NOT connect a power supply of more than 6v to the P22; you will certainly blow the IC if you do so, and you will also probably damage or destroy the servo or other device which is connected to it at the same time. If you are testing a speed controller which has Battery Eliminator Circuitry included (BEC) then you should NOT connect the battery box to the P22; it will get its power supply from the motor drive battery via the BEC. The pulse-width generated by P22 is beyond the range of most Electronic Speed Controllers at its extremes of movement, so don't be alarmed if your ESC shuts down the motor when you apply a full turn to the rotary knob. It's to be expected, and you haven't broken anything!

RECOVERY SERVICE

A recovery or repairs service ensures that in the event of a mishap you will not be left with a dead project. The Service Charge for this unit is £9.00 including parts cost (POST FREE IN UK). All returns should include full Credit Card details (Name & Address of cardholder, Card number, Expiry date and Card Security Number)

ACTION R/C ELECTRONICS, 1 Llwyn Bleddyn, Llanlechid, Bangor LL57 3EF

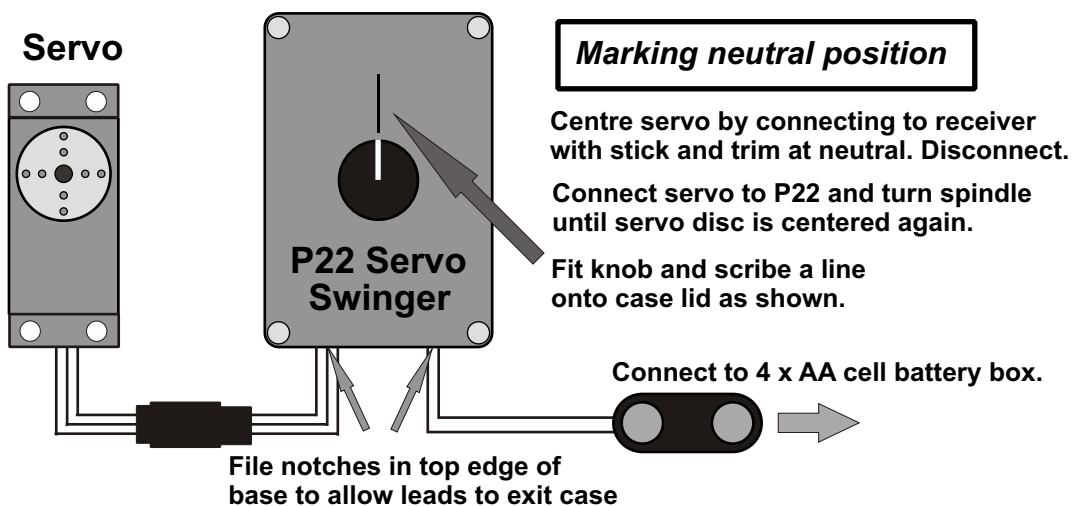

The small print.....
ACTION R/C Electronics guarantee all products to be free from manufacturing defects for 12 months from date of purchase. This does not cover suitability for specific applications; components worn or damaged by use, tampering or incorrect connection; alteration to original components; damage to batteries or other equipment through use; misuse, or shipping damage. Where goods are found to be faulty, the customer shall return them to ACTION R/C Electronics in their original condition and with their original instructions, packaging etc. Our liability is limited to repairing or replacing goods to their original specification and will not exceed the cost of the goods. By using the product the user accepts all liability. Where a fixed repair charge is applicable, ACTION R/C Electronics shall undertake repairs to the extent that they are judged economically viable. Where such is not the case then the customer will be offered the option of crediting the repair charge towards the cost of a new unit or having the faulty unit returned and the charge refunded (less the cost of return carriage). We reserve the right to modify this guarantee without notice.

P22 SERVO SWINGER
Instructions for kit version

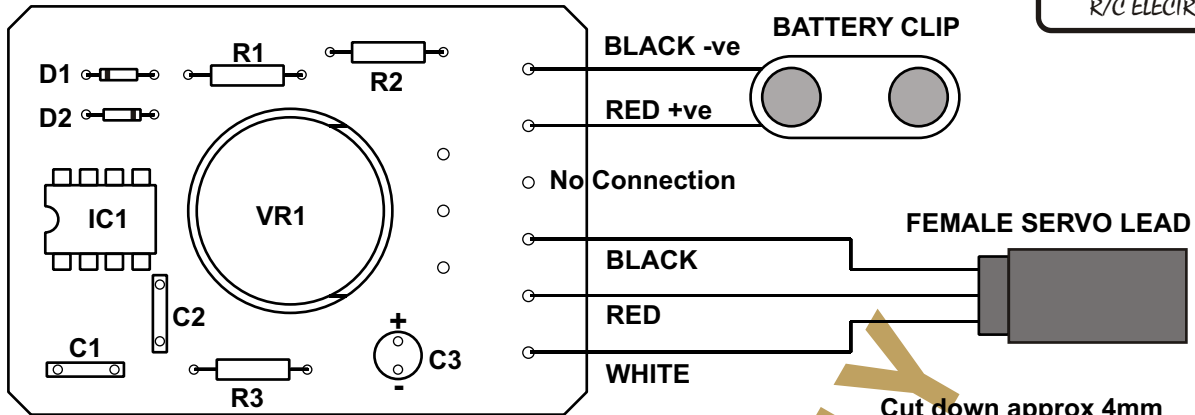

NOTE: VR1 IS SOLDERED TO COPPER SIDE OF PCB

Component Layout & Wiring

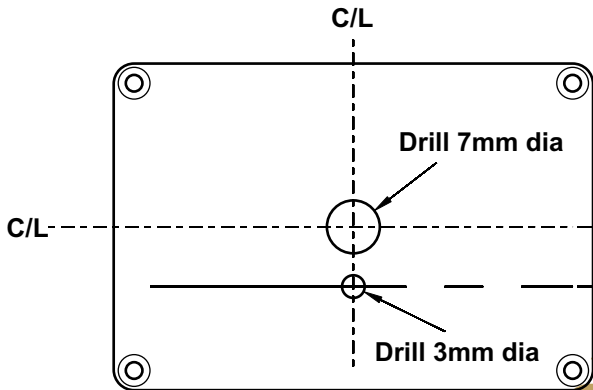

Drilling holes in case lid

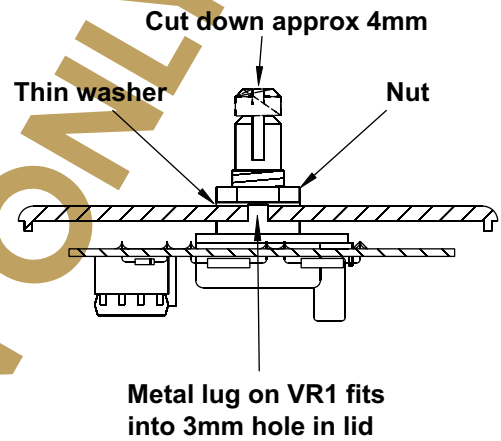

Fitting PCB to case lid

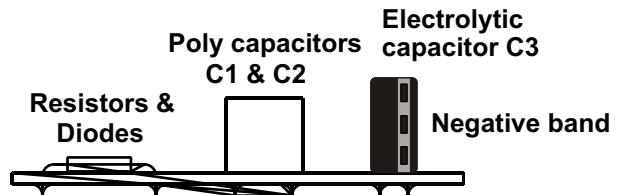

Component Mounting Details

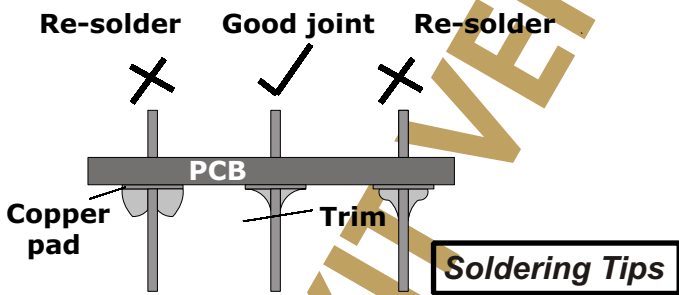

Soldering Tips

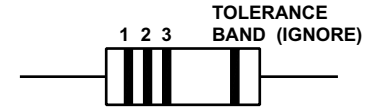

Resistor colour bands

PARTS LIST

- IC1
- D1,2
- R1
- R2
- R3
- VR1
- C1
- C2
- C3
- BATTERY BOX
- BATTERY CLIP
- SERVO CONNECTION
- CASE TYPE
- PCB

- 555 IC & 8-pin DIL socket
- Signal diodes 1N4148
- 680K resistor 1/4 W (BLUE/GREY/YELLOW)
- 33K resistor 1/4 W (ORANGE/ORANGE/ORANGE)
- 150 Ohm resistor 1/4 W (BROWN/GREEN/BROWN)
- 47K Linear Carbon-Track Control Pot + Push-on Knob
- 0.033 uF Poly Capacitor (Marked 0.033)
- 0.022 uF Poly Capacitor (Marked 0.022)
- 22 uF 16V Electrolytic Capacitor
- 4 X AA, with stud connectors
- Moulded type, with stud connectors and 150mm wires
- Universal "female" socket (3 pins) and leads
- RX2009, with screws and ACTION badge
- P22

P22 Kit Instructions

PCB

The PCB for this Project is fully prepared and requires no additional work. The large 18mm hole in the centre is preformed to clear the body of the control pot.

CASE

The case for this project, as supplied, is not cut or drilled in any way. It is moulded in ABS which is very easily worked with normal modelling tools. You will need to drill a 7mm hole for the pot spindle; a 3mm hole for the locating lug on the pot (which stops the body of the pot from rotating) and further holes or slots for the battery input and servo output leads.

TOOLS

For construction you will require a soldering iron and flux cored solder; a small pair of wire cutters; a small screwdriver for adjustment and connection. A good level of light is recommended.

PARTS

All the parts for the kit should be laid out on a clean surface so that they can be correctly identified.

The potentiometer (or "pot") is a variable resistor. Together with its push-on knob, this pot will control the signal which is sent to the device being tested, be it a servo, electronic speed controller or one of the range of ACTION switchers. The shaft may need to be cut down in length to fit the knob supplied.

The three resistors are colour-coded in accordance with the Parts List.

The Integrated Circuit IC1 is an NE555 device and has that number printed onto its top face. It is fitted into an 8-pin DIL socket which is soldered into the PCB. The IC should be fitted as the last step in construction.

The two small square Poly Capacitors are marked 0.033 (C1) and 0.022 (C2). They are not polarised and can be fitted either way around in the PCB.

The Electrolytic Capacitor C3 is marked with its value (22 uf) and working voltage (16v) and a vertical bar with Negative signs on it which signifies which leg goes to the negative. The opposite leg of the capacitor, of course, goes to the positive. The capacitor polarization is shown on the drawing.

The small glass Diodes D1 and D2 have a dark bar marked at one end. This is clearly marked on the drawing and the diodes must be fitted the correct way around.

CONSTRUCTION

As the PCB layout for this project is well spaced and most components can easily be fitted at any stage of the construction, a full list of instructions is not required. Just points to watch out for have been listed. Components can be fitted in whatever order you wish. "Soldering Tips" is an attempt to help the inexperienced to recognise a satisfactory soldered joint. As you finish fitting each component, clip off the surplus wire on the back of the PCB.

When fitting IC1, ensure that the small notch at one end is in accordance with the illustration.

The polarity of capacitor C3 must be observed, see Mounting Detail. The + and - are marked on the drawing. The resistors and non-polarised capacitors can be fitted either way round; just ensure that the correct value goes in the right place.

Note that the pot is soldered onto the *opposite* side of the PCB to the other components, so that the tinned copper-clad side of the board faces the underside of the lid when the unit is fitted into the case. Carefully bend the three silver solder-tags so that they fit into the holes in the PCB, then solder them in place. MAKE SURE THAT THE RIVETS WHICH HOLD THE CONTACTS TO THE POT DON'T TOUCH THE TRACK OF THE PCB UNDERNEATH. The nut on the pot holds the whole assembly in place under the lid.

When you have finished building the unit, the rear of the board can be cleaned with something like an old toothbrush and some spirit cleaner. Then check all over the soldered side of the board for good joints and no solder bridges between tracks. Time now to tackle the case; not a lot to it really, it's just a matter of drilling the two holes for the pot and its locating lug as shown in the drawing, and some smaller holes at the appropriate positions along the end of the case for the battery and servo leads. I personally just file a narrow slot at the top end of the case.

P22 SERVO SWINGER

PHOTOGRAPHIC BUILD SEQUENCE FOR KIT VERSION ONLY

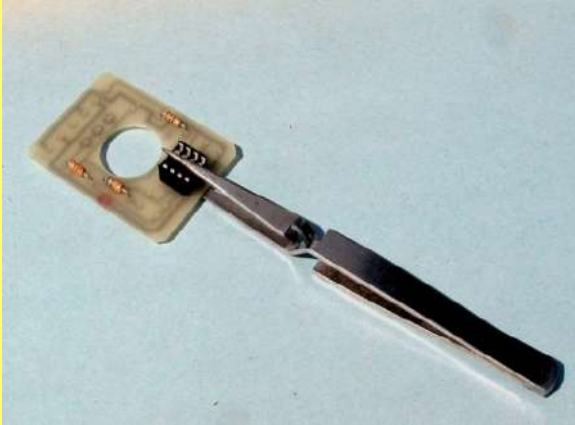

Picture 1: Resistors and IC socket

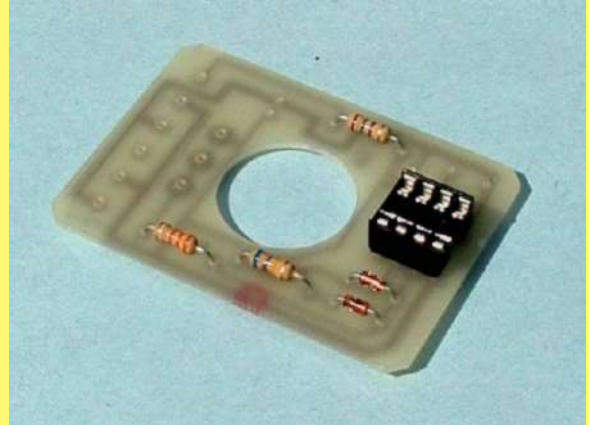

Picture 2: Diodes added



Picture 3: Capacitors added

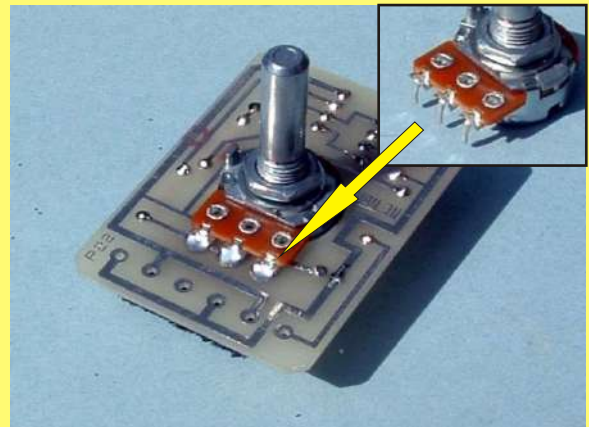

Picture 4: Bend tags (inset) and solder pot



Picture 5: Mark out and drill case lid



Picture 6: Solder leads and fit PCB to lid

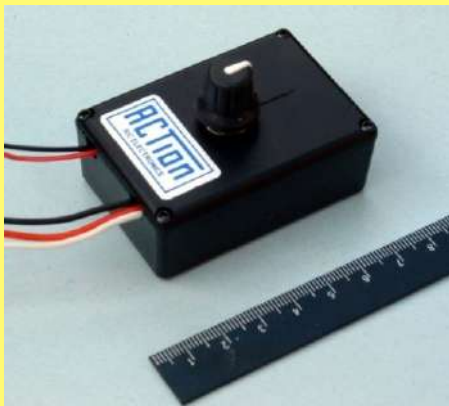

Picture 7: File slots in case for leads

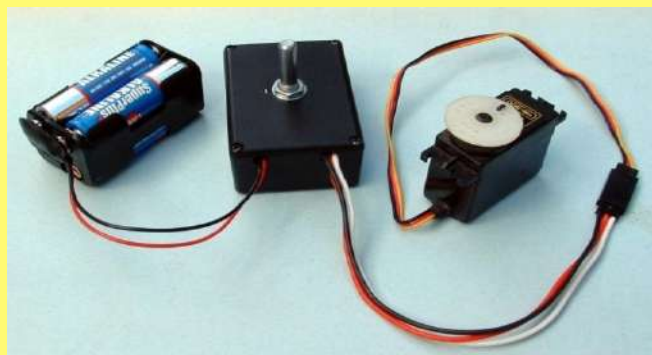

Picture 8: Set neutral using servo; fit knob